

CF20 Series 0.50mm(.020") SMT ZIF FFC/FPC Connectors

- ⊙ Insulation: High temperature plastic UL 94V-0, Color Nature
- ⊙ Slider: High temperature plastic UL 94V-0, Color Black
- ⊙ With fixed metal tabs to secure connector in place

RoHS Compliant  

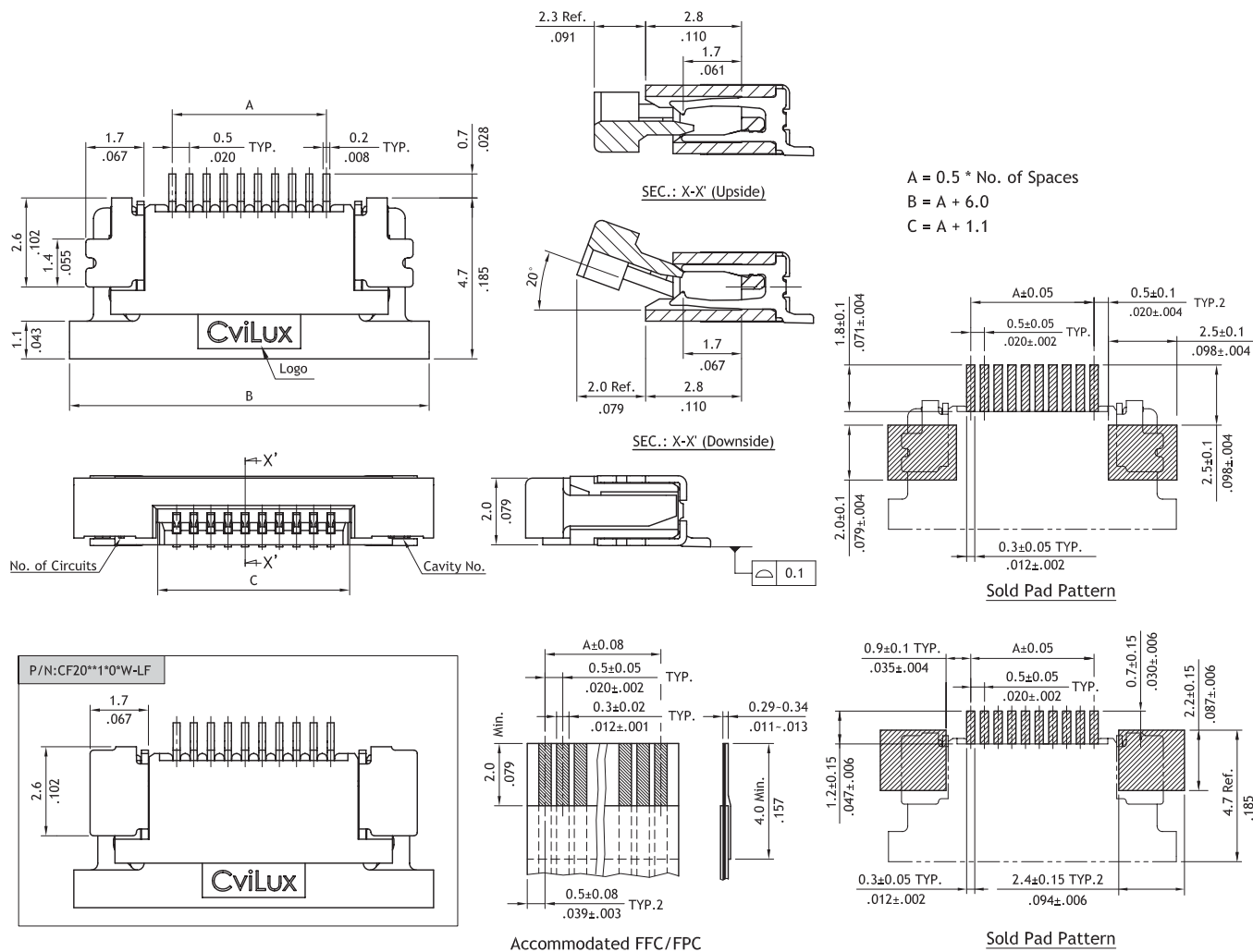
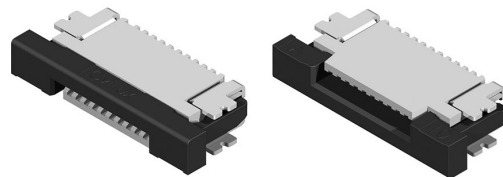

Ordering Code

1 **2** **3** **4** **5** **6** **7** **8**
CF 20 55 1 D 0 R 0 - LF

- | | | |
|---|--|---|
| <p>1 Series No.</p> <p>2 Circuits : 04 to 55</p> <p>3 Plating code:
1= Tin over Nickel</p> | <p>4 Contact style:
U = Upside contact
D = Downside contact</p> <p>5 Color: 0 = Nature</p> <p>6 Packing options:
R = Tape & Reel
T = Tube</p> | <p>7 Other options:
0 = Standard
W = Intensive tabs
* Special options consult manufacturer</p> <p>8 Process:
-LF = For Lead Free soldering process
-NH = For Lead Free soldering process and Halogen-Free</p> |
|---|--|---|